

CARE

Your loudspeakers have a fine finish and should be treated like fine furniture. They will require only occasional cleaning. For wood finishes, use a slightly damp cloth to wipe the loudspeakers clean. Using any other cleaning method will most likely result in damage to the finish. Lint and dust may be removed from the grills by removing the grills from the loudspeakers and lightly vacuuming them with a vacuum tip that is clean and has soft bristles. Alternatively, a clothes lint remover of the masking tape variety may be used to remove lint and dust.

To clean the grills you must remove them to avoid damage to the tweeters and woofers. To remove the grills, grasp the cabinet firmly with one hand. Use the other to grasp the top of the grill, then the bottom. The loudspeakers can be used without the grills but you should ensure that the drivers will not be damaged.

If bare wire or spade terminal connections are used to connect the loudspeakers to the amplifier, the terminals should be firmly hand tightened and checked periodically to ensure tightness.

WARRANTY

All NSM Audio loudspeaker systems are intended for use in the reproduction of music and are warranted against defects in materials or workmanship that occur in normal use for ten (10) years from the date of original purchase. NSM Audio will repair, replace or adjust defective parts for the original owner without charge for parts or labor, provided the loudspeaker is returned at the owner's cost to the dealer from which the loudspeaker was purchased or to NSM Audio. Please call us prior to any return shipments.

This warranty does not apply to damage that results from abuse or misuse, accidents including those that occur during shipping, and any damage that results from repair or modification by anyone not specifically authorized to make repairs by NSM Audio. In order to claim coverage under this warranty, you must provide proof of purchase in the form of a sales slip or proof of product registration with NSM Audio. This warranty gives you specific legal rights, and you may have other rights which vary from state to state.

NSM AUDIO

P.O. Box 13396, Research Triangle Park
North Carolina, USA 27709-3396
Phone: 919-244-8777 Fax: 206-339-9034

www.nsmaudio.com

NSM AUDIO

hear the possibilities

OWNER'S MANUAL

TWO CHANNEL STEREO

Basic two-channel stereo loudspeaker placement.....page 2

Amplifier requirements and power response.....page 7

Alternative stereo placement.....page 8

HOME THEATER AND SURROUND SOUND

Surround placement.....page 11

Center channel placement.....page 14

Alternative surround placement.....page 15

CARE.....page 16

WARRANTY.....page 16

UNPACKING

Fold the flaps along the sides of the carton and gently invert the carton on protective material on the floor. Lift off the carton to reveal its contents. We suggest you retain all packaging materials. Carefully review all accompanying literature before proceeding.

BASIC TWO-CHANNEL STEREO LOUDSPEAKER PLACEMENT

Placement is a very important determinant of loudspeaker performance. No matter how well designed your loudspeakers are, if they are not properly placed in the listening area you will not realize their performance capabilities. Since variations in speaker placement can produce dramatic difference in the way music sounds, it is worthwhile to spend some time experimenting with which placements work best in your listening room. Optimal stereophonic placement is treated in considerable detail in the section on Alternative Stereo Placement. For those of you who have a dedicated listening room or if you want to experiment please refer to that section.

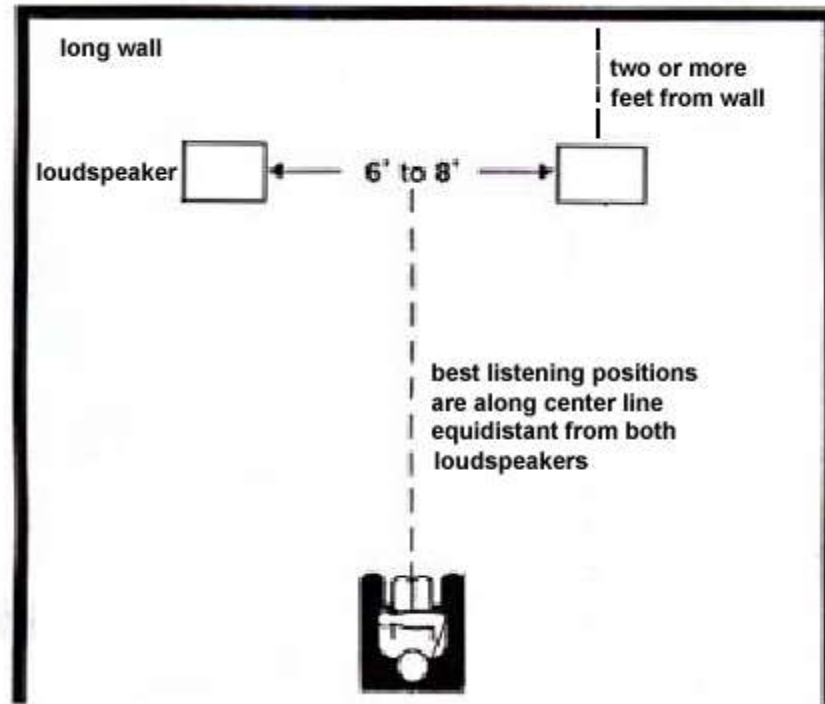

Basic Placement

Most people however do not have the luxury of a room that they can dedicate strictly to listening to music. They cannot rearrange the room around the music system. Listening to music must coexist with the other pursuits that occur in the living room among the furniture and other fixtures. For these situations the best compromise is a basic setup where the loudspeakers are placed fairly close to one wall and a couch or chair that is opposite to them is the listening position.

ALTERNATIVE 5.1 SURROUND LOUDSPEAKER PLACEMENT

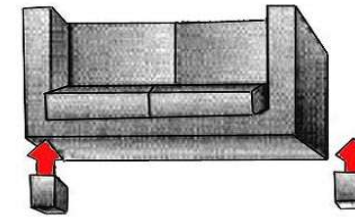

You can mount the surround loudspeakers on the back wall above the listeners and aim them forward.

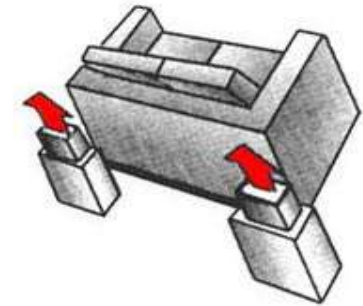

You can place the surround loudspeakers behind the listeners and aim them upwards towards the ceiling.

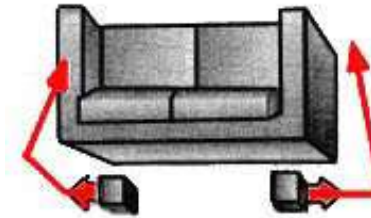

You can mount the surround loudspeakers on the back wall above the listeners and aim them away from each other.

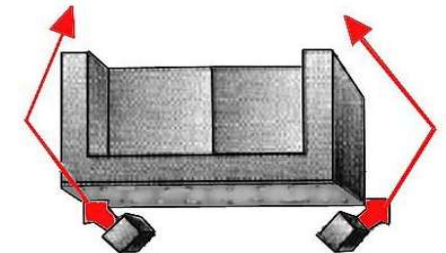

You can mount the surround loudspeakers on the back wall above the listeners and aim them to the side walls to reflect the sound forward.

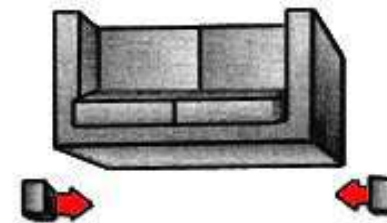

You can mount the surround loudspeakers on the back wall above the listeners and aim the loudspeakers at each other.

Remember, if you cannot mount the loudspeakers on the back wall, you can mount them on loudspeaker stands.

CENTER CHANNEL PLACEMENT

High quality accurate loudspeakers such as our Model 7 and Model 5 that radiate sound evenly will let you hear voices clearly and centered in your home theater system. The center loudspeaker has to be accurate because it is reproducing all the information produced by the other front loudspeakers in addition to dialogue. Without the center channel speaker only the person in the "sweet spot" will hear dialogue that is centered. For other listeners the dialogue will drift towards the speaker they are sitting closest to. Your center channel loudspeaker should be "timbre-matched," with the left and right front speakers.

The best placement for the center channel is directly on top, or directly below the TV, recessed enough to make the center channel and the front loudspeakers equidistant from someone sitting directly in front of the TV. The center channel loudspeaker should be tilted, if necessary, so that its top and bottom edges are the same distance from the listener.

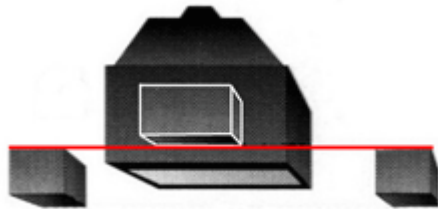

Preferred Center Channel Placement

A common alternative placement is to align the front of the loudspeaker with the TV. While this placement is not optimal, it is visually more harmonious with the TV.

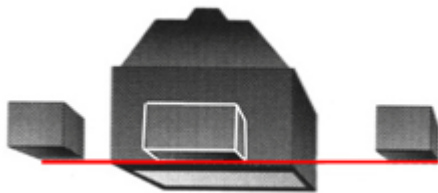

Alternative Center Channel Placement

For flattest frequency response, position the loudspeakers to ensure the tweeters are close to the height of the ears of the seated listener as possible (if necessary use loudspeaker stands to achieve the desired height). A height of roughly 35 inches from the floor to the tweeter will generally match the height of the ear of a person of average height who is seated on a couch. Place the loudspeakers six to eight feet apart and eighteen inches or more from the rear wall. For greater bass response place the loudspeakers closer to the rear wall. If you cannot realize this basic placement, moving the loudspeakers even six to twelve inches from the rear wall will significantly improve the depth of the stereophonic soundstage. Consult the section on "Alternative Stereo Placement" for techniques to improve on this basic placement.

No two listening rooms are the same. Therefore you are encouraged to spend some time experimenting with which placements work best in your listening room. Trust your ears and be willing to experiment freely. Start with our basic recommendations.

What About Placement on Bookshelves and in Wall Cabinets?

Placement on bookshelves and in wall cabinets will generally reduce the soundstaging and imaging performance of loudspeakers, while it can often provide a richer, more full-bodied sound. Because our minimonitors and bookshelf loudspeakers are acoustic suspension designs they are the most well suited loudspeakers for placement on bookshelves and in wall cabinets. Because of their acoustic suspension design, our small loudspeakers are widely used in custom installations, where the loudspeakers are often fitted into custom wall units, with excellent results.

Remember, for any placement, try to maximize the performance of the loudspeakers. Moving them just a few inches and changing the angle of the loudspeaker can provide noticeable improvements in performance.

SUBWOOFER PLACEMENT

Placing a subwoofer near to walls or in corners will generally reinforce bass response. Although, in some cases the resulting bass response can be unpleasant. For the most audiophile response, locate the subwoofer on the same plane between, and slightly ahead of, the front satellite or main speakers. For convenience, the subwoofer may be located away from the main or satellite speakers. For greatest bass reinforcement, locate the subwoofer near to a wall or corner. Once placement is determined, if the subwoofer has a phase switch, engage the phase switch to find the setting that provides the loudest output and coherence with the satellites. In the correct setting the speaker system will sound louder and produce more bass. Adjust the crossover switch to get the best acoustical match with the satellite speakers. For more extensive information on setting up subwoofers, refer to the users manual that is shipped with your subwoofer.

CONNECTING THE LOUDSPEAKERS TO THE AMPLIFIER

Place the loudspeakers in the anticipated position. If you are using speaker stands, place the stands in the appropriate position and place the loudspeakers on top of them. Be sure the amplifier is switched off before connecting the loudspeakers to the amplifier. Observe polarity on the amplifier or receiver and the loudspeaker by identifying the positive and ground binding posts or connectors. On the loudspeakers, the positive connectors are coded red, the grounds are coded black.

Our loudspeakers use high quality five-way gold-plated binding posts that are suited for just about any connection. They accept heavy gauge bare wire, banana plugs, spade lugs, or pin terminators. Use equal lengths of hookup wire to connect the loudspeakers to the amplifier. We recommend low gauge oxygen free copper wire or

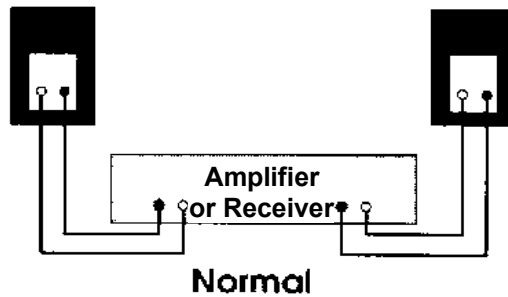

other high quality speaker cables. For loudspeakers located up to 25 feet from the amplifier or receiver we recommend equal lengths of 16 gauge oxygen free copper wire or other high quality loudspeaker wire. For loudspeaker located more than 25 feet away from the amplifier or receiver we recommend 14 gauge wire.

Connect the left channel wires from the amplifier or receiver to the speaker that is to the left of the listening position. Connect the right channel wires to the speaker that is to the right of the listening position. Be sure the loudspeaker binding posts are securely hand-tightened if you are using bare wire connections. Also ensure there are no loose strands of wire that can short circuit the binding posts (touch the other binding post). You should now turn on your system and do a listening test to ensure the system is hooked-up and functioning correctly. Use your amplifier balance control to ensure the loudspeakers are connected in the proper left-right orientation. Make sure the system is connected in proper phase. If the system is connected out of phase the volume and bass response will be diminished. To check for correct polarity, place the loudspeakers facing each other a few inches apart. Switch your amplifier to mono. Play a recording that has deep bass then switch around the connections on one loudspeaker. Correct polarity will result in stronger bass response.

SURROUND LOUDSPEAKERS

First, let's clear up a misperception, that only specially designed loudspeakers, such as THX certified loudspeakers, can work well in surround or home theater systems. Nothing could

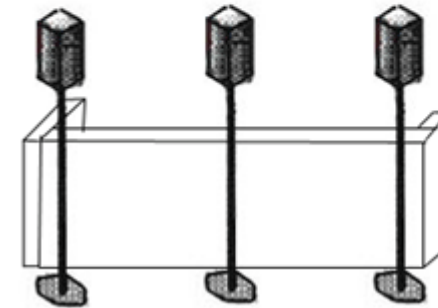
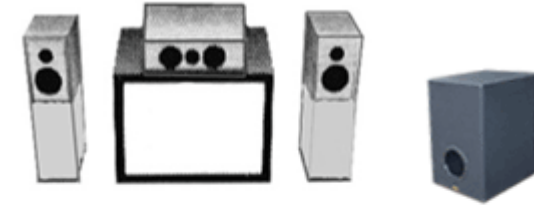

6.1 Surround Placement

be farther from the truth. And the various arguments for such loudspeakers are mostly marketing ploys. For certain, if you intend to use a loudspeaker near (generally, less than a foot and a half) from a CRT screen such as a TV, you should use a shielded loudspeaker to prevent magnetic interference from the magnet that is on the transducers (drivers) in the loudspeaker from reaching the CRT. Most of our loudspeakers are magnetically shielded. Magnetic interference will cause color distortion and can permanently damage CRTs. Some small loudspeakers can be used less than a foot from a CRT and not produce any magnetic interference, because of the small magnets they use. If you don't intend to place the loudspeakers very close to the CRT, they do not have to be magnetically shielded.

Buy the highest quality loudspeakers you can afford. Remember loudspeakers are the most critical pieces of equipment in the chain of the equipment that forms your home theater system. By highest quality we mean well designed and well constructed, not pricey. A high quality loudspeaker should produce neutral coverage of the frequency spectrum. It should radiate sound fairly evenly in all directions. And it should reproduce a stereophonic image and soundstage accurately.

listening area. Our Model 5, 7, and 10 loudspeakers are ideal for this purpose because they are outfitted with a receptacle for “no-fuss” attachment to Omnimount™ brackets. However, you can use any of our small loudspeakers for this purpose.

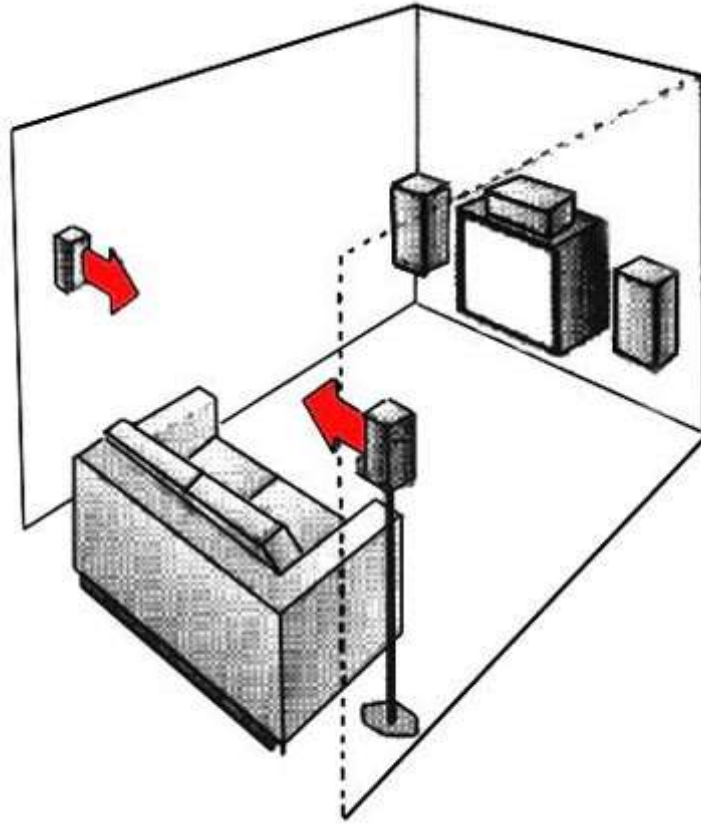

5.1 Surround Placement

6.1 SURROUND PLACEMENT AND SURROUND LOUSPEAKERS

A 6.1 surround speaker system adds a center channel loudspeaker in the rear for a more revealing sound. Any of our small loudspeakers may be used as a rear center channel loudspeaker.

CONNECTIONS FOR BI-WIRING AND BIAMPING

If your loudspeaker is equipped with bi-wire terminals, bi-wiring can result in improved performance, including less distortion, especially in small loudspeakers. Bi-wiring requires the use of four equal lengths of loudspeaker hook-up wire, two per channel, to connect the amplifier to the loudspeakers. First remove all the bridging brackets from between the loudspeaker binding posts. For the left channel speaker, connect one set of positive and ground wires to the bottom row of binding posts. Connect the other set to the top row of binding posts. Make the respective connections to the right channel loudspeaker.

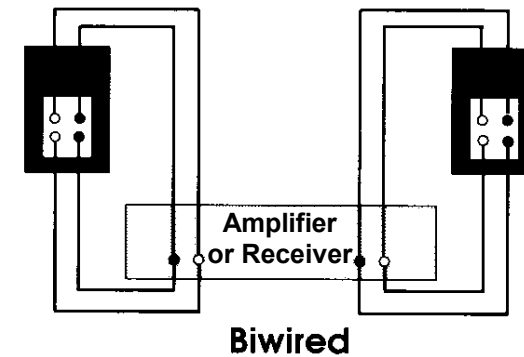

Bi-amping can further enhance the performance of the system. To bi-amp, remove all the bridging brackets from between the loudspeaker binding posts. Use one amplifier or receiver to power the tweeters and the other to power the woofers. For the left channel speaker, connect one set of positive and ground wires between the tweeter binding posts and the left channel speaker output terminals on the amplifier used to power the tweeters. Connect the other set between the woofer terminals and the left channel loudspeaker output terminals of the amplifier used to power the woofers. Make the respective connections to the right channel loudspeaker.

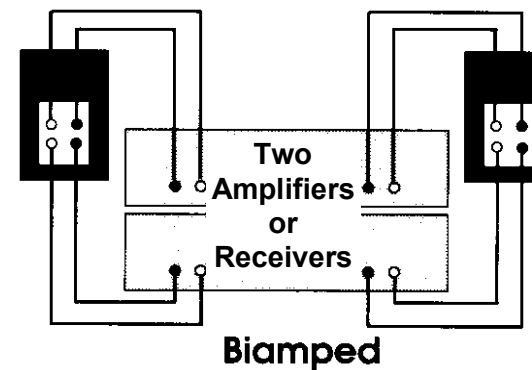

CONNECTIONS FOR SYSTEMS WITH AN ACTIVE SUBWOOFER THAT USE THE SUBWOOFER'S HIGH PASS FILTER, OR CONNECTIONS FOR SYSTEMS WITH A PASSIVE SUBWOOFER

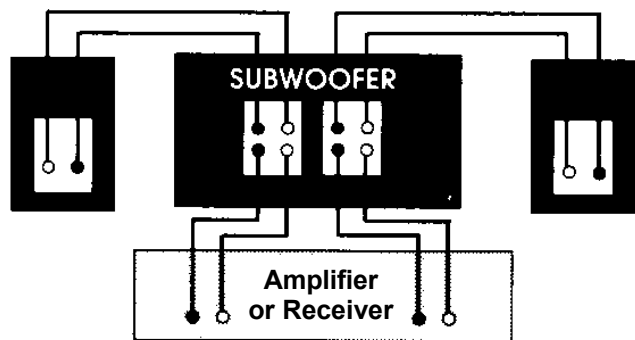

Connect two equal-length sets of loudspeaker wire, one per channel, between the amplifier and the input row of binding posts on the subwoofer. Observe polarity. Connect another two equal-length sets of wire, one per channel, between the output row of binding posts on the subwoofer and the terminals of the respective loudspeakers used as satellites.

CONNECTIONS FOR SYSTEMS WITH AN ACTIVE SUBWOOFER USING LINE LEVEL CONNECTIONS

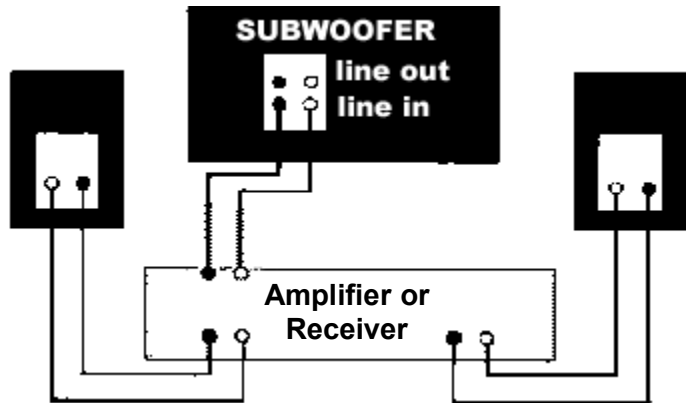

Connect two equal-length sets of line level interconnects, one per channel, between the amplifier or receiver's RCA preamplifier outputs and the appropriate RCA inputs connectors on the subwoofer. Some receivers have a single line level output for active subwoofers. Connect this single output to the right (red) input on the subwoofer or refer to the owners manual for the subwoofer. If preamplifier outputs are not available on the amplifier or receiver, use high-level or loudspeaker connections between the amplifier or receiver

STEP #3 ESTABLISH SOUNDSTAGE FOCUS

To get the performers to come into focus (as with a camera) requires two people. The other person should rotate the loudspeakers, one at a time, in a rapid fashion on the axis indicated by the arrows in figure B, while the listener checks for greater or lesser focus of the stereophonic image. After a small amount of practice the listener will get a sense of the right position. Do the other loudspeaker and trust your judgment. You will hear the difference.

STEP #4 ESTABLISH SOUNDSTAGE BALANCE

In cases where the stereophonic image is more dominant on one side of the room, the other person in figure B should move the loudspeaker on the weaker side of the soundstage forward along the axis shown in figure C, Move the loudspeakers in increments of 1/16" to 1/8" until the best soundstage balance is achieved.

The four corners of the room between the walls and the ceiling, often cause defocusing of the soundstage. Therefore, the four corners are a good place to start treating the room with absorbent materials if you still experience lack of soundstage focus or if you want the best soundstage focus.

SURROUND PLACEMENT

5.1 AND 6.1 SURROUND PLACEMENT AND SURROUND LOUSPEAKERS

When putting together a Dolby digital 5.1 home theater system, you should ensure that the five main loudspeakers-left, center, right, and two surrounds can reproduce the same sound. Loudspeakers that have perfectly matched timbre (generally those using the same or similar tweeters and woofers and crossover design) will give the best results. However, the main loudspeakers do not have to reproduce low bass. With a good subwoofer dedicated to reproducing low bass and adjusted for the best integration with the main loudspeakers, it can be virtually impossible for you to determine which of the loudspeakers is reproducing low bass. You could use large floor standing loudspeakers that are capable of reproducing low bass, but that is not necessary, because you can achieve excellent results with five small satellite loudspeakers and a dedicated subwoofer. Most surround receivers have a switch to match the output of the receiver to small or large loudspeakers. In general this switch should be set to "small" if you are using a subwoofer.

You will hear different opinions about where to place your rear surround loudspeakers. The ideal placement is on adjacent walls above the listening area as shown in the following graphic. The surround loudspeakers may be wall-mounted. Where wall mounting is undesirable, you can place the loudspeakers on loudspeaker stands or use small floor standing towers. Another alternative is to use pivoting adjustable brackets (such as Omnimount™) to mount the loudspeaker on the ceiling and angle them downward over the

surprising how many people have never been exposed to the effect this placement generates. The middle position has the second deepest soundstage, and is often acceptable. Rear quarter placement is the most acceptable compromise when décor issues limit placement choices. Having determined the best position that suits your life style and proper bass response, let's go to step two.

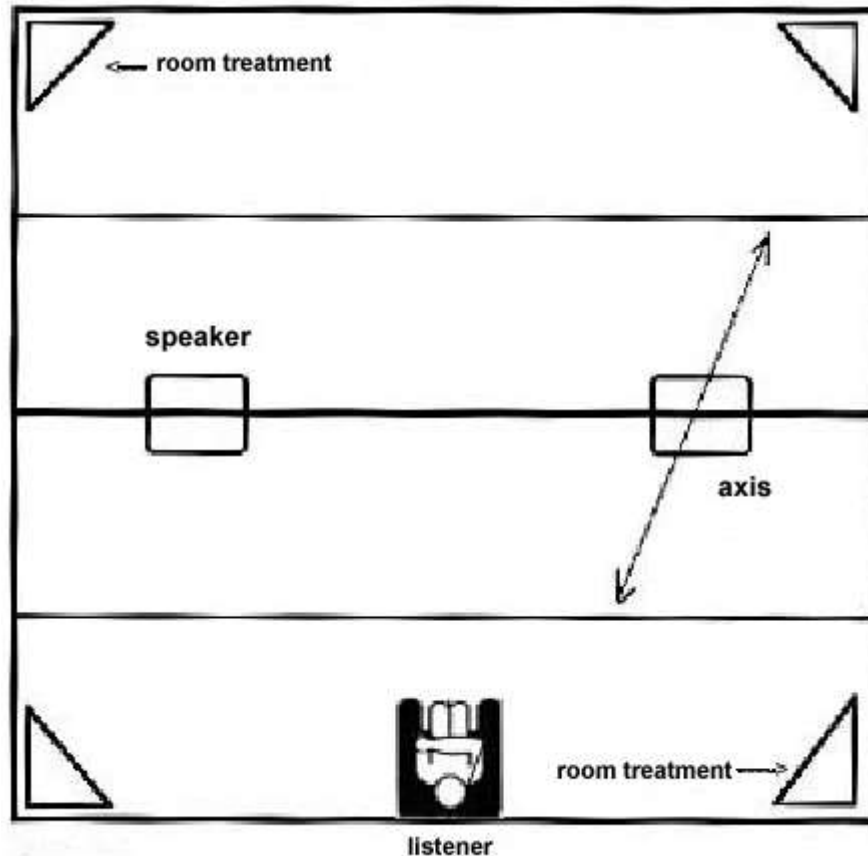

FIGURE C

STEP #2 ESTABLISH SOUNDSTAGE WIDTH

Take the loudspeakers along the axis you have chosen in Step 1 and have someone move them toward the side walls, one at a time, while you are listening. You will notice that the soundstage gets wider. At a certain point you will experience the center of the soundstage falling out, then you know that have gone too far. Move one or both of the loudspeakers toward the center a little at a time to re-achieve the best balance.

and the subwoofer. Then connect two equal-length sets of loudspeaker wire, one per channel, between the amplifier or receiver loudspeaker output terminals and the terminals of the respective loudspeakers used as satellites.

CONNECTIONS FOR SYSTEMS WITH TWO SUBWOOFERS

Ideally, the two subwoofers should be placed between the loudspeakers. However, they may be placed anywhere in the room for convenience. Use two equal-length sets of RCA terminated interconnects, one per channel, to connect the amplifier or receiver preamplifier outputs to the subwoofers. Use two equal-length sets of loudspeaker wire, one per channel, to connect the left and right channel loudspeaker output terminals on the amplifier or receiver to the left and right loudspeakers used as satellites.

AMPLIFIER REQUIREMENTS AND POWER RESPONSE

Amplifier power requirements depend on a combination of room size, desired listening level and interaction between the amplifier or receiver and the loudspeakers. This makes it impossible to make hard and fast amplifier or receiver power requirement recommendations. The recommended power requirements that we make reflect what should be needed under average listening conditions. In general, low powered amplifiers pose more risks of damage to loudspeakers than high powered ones. As a general rule a more powerful amplifier is preferable to one with less power. However, with high powered amplifiers you can damage loudspeakers by driving them beyond their capacity.

How loud you can play loudspeakers is determined mainly by the loudspeaker's size and the response accuracy you desire. Please note that in order to provide the purest signal path to the loudspeakers, no protection circuitry is included in our loudspeakers. We use extremely high quality parts in all of our loudspeakers. Nonetheless, at the first sign of audible distortion, reduce the volume of your amplifier or receiver. Loudspeakers can be damaged by unusually high volume bass passages when the loudspeakers are being played at extremely loud levels.

All loudspeakers have a finite mechanical limit. Driving loudspeakers beyond their limit can cause serious damage. Distortion is evidence that either the loudspeaker or the amplifier is reaching its limits. Distortion produced by an amplifier is often heard as harmonics that are not part of the music. A clicking noise from the loudspeaker is an indication that the loudspeaker has reached the mechanical limits of its travel and the volume must be reduced immediately.

ALTERNATIVE STEREO PLACEMENT

This section is based on Guidelines for Setting Up Speakers by the late Leo Massi, formerly of Sound II, North Dartmouth, Massachusetts (used with permission)

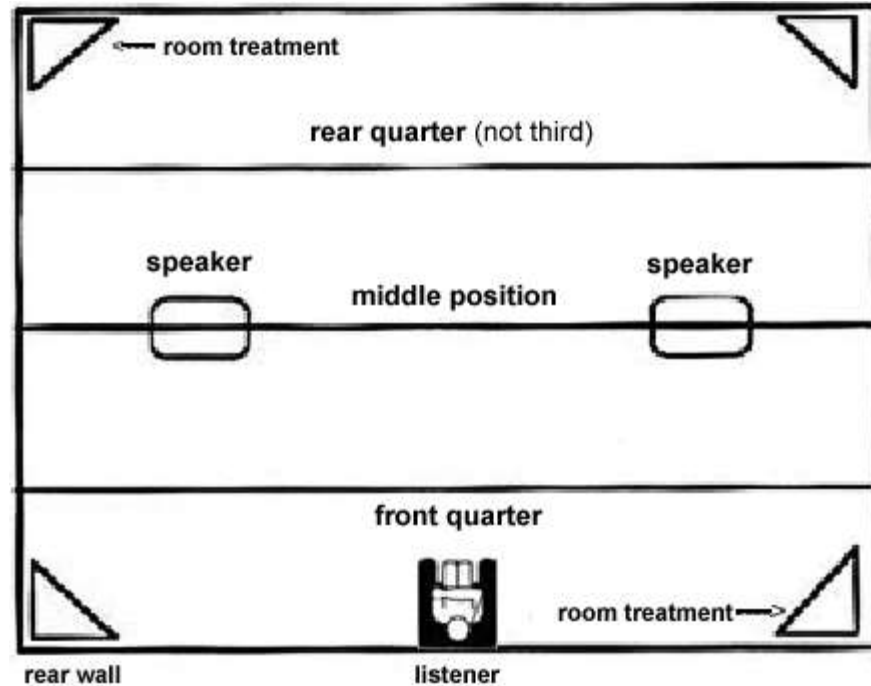

FIGURE A

STEP #1 ESTABLISH PROPER BASS RESPONSE

It is not always true that one gets the best bass near the wall. For example, corner positioning may substantially enhance bass response below 40 to 50 Hz, yet may drastically reduce mid-bass output at the listening position. If positioning causes standing waves or "suck-outs" the tonality of the presentation will be off. Therefore, getting the best bass response is the first step to obtaining the best performance from your loudspeakers. If you position loudspeakers along the wider wall you will get a wider soundstage. If you place them along the shorter wall, it is unlikely you get as wide a soundstage, yet, if you can place them closer to you, the listener, you will experience a very deep soundstage. In any case, the width of the soundstage should go well beyond the two speakers.

There are three positions suggested in Figure A: good, better and best. While a lot will depend on your room, you should try to experiment with these rules. The listener should be within three feet from the rear wall to minimize de-focusing reflections from the rear wall. It also helps to have some sort of sound dissipating material on the wall directly behind the listener's head.

Somewhere within a foot to an inch of the exact middle of the room will give you the best overall bass response.

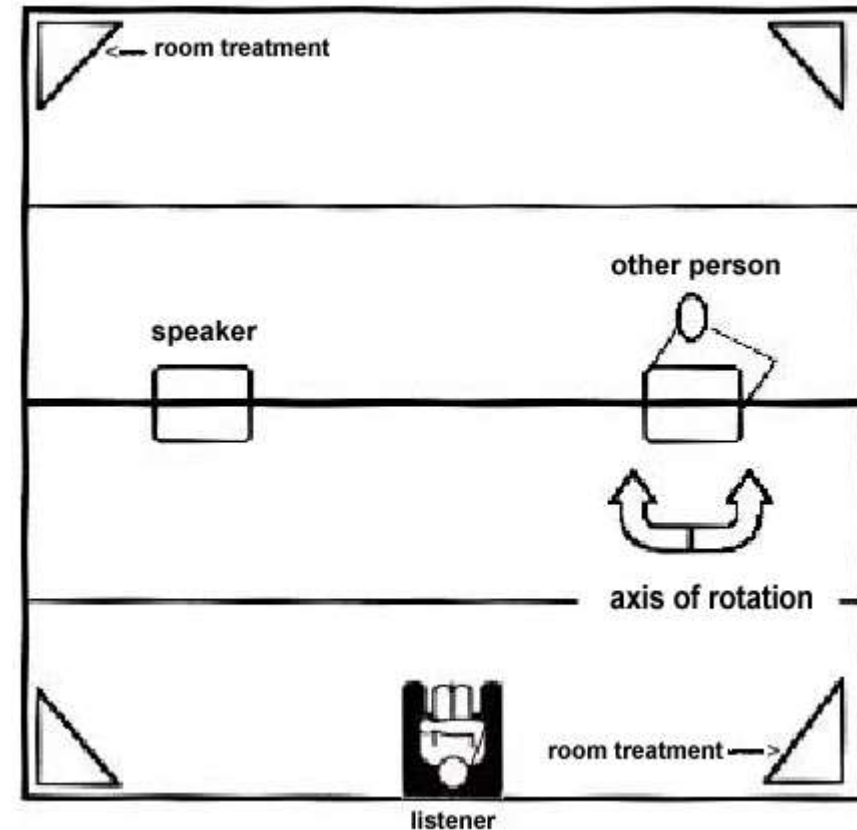

FIGURE B

Front or rear quarter positions will be close seconds. These distances should be measured with a tape and, while slight deviations should not significantly affect the sound, being a foot or more off will most likely affect bass response and overall tonality will be off.

The front quarter position takes most of the back of the room out of play and gives the most holographic sense of depth. This is referred to as "nearfield listening", and it is always